

## RSR-4445 Industrial / High Pressure

### GENERAL DESCRIPTION

YORK® Refrigerant Storage/Recycling System (RSR) offers all the features a field service technician needs. These compact, portable, self-contained units are easy to operate for fast chiller evacuation. Plus, capacities are ARI certified to assure performance as specified. These units are self-contained packages specifically engineered to provide refrigerant recovery capabilities for commercial and industrial applications requiring serviceability. It consists of a refrigerant compressor, oil separator, storage receiver, water-cooled condenser, heater, filter drier and necessary valves and hoses to remove, replace and distill CFC and HCFC refrigerants. All necessary controls and safety devices are permanently mounted. The RSR package is permanently mounted or made portable (via swivel casters with lock brakes).

### TECHNICAL DATA

#### GENERAL

YORK® Model Number RSR-4445

#### Applicable Refrigerants

|      |          |
|------|----------|
| CFC  | 12 / 500 |
| HCFC | 22       |
| HFC  | 134a     |

Maximum Working Pressure 300 psig

Motor Horsepower 10 HP

#### DIMENSIONS

|                    |           |
|--------------------|-----------|
| Length             | 112"      |
| Width              | 42"       |
| Height             | 88"       |
| Total weight (dry) | 4,300 lbs |

#### ELECTRICAL DATA

|                   |                      |
|-------------------|----------------------|
| Standard Voltages | 460V / 3Ø / 60Hz     |
| Connections       | Locking, NEMA L16-30 |



#### UNIT FEATURES & BENEFITS

AHRI Certified Industry Performance Leader  
Designed for High Pressure Refrigerant Systems  
Refrigerant containment while servicing chiller to prohibit venting & simplify Clean Air Act compliance  
YORK "K" Oil Charged  
Standard 1-year parts warranty  
ASME Boiler and Pressure Vessel Code Stamped

#### UNIT ACCESSORIES

Eight (8) feet of Refrigerant Hose with valves  
30A, 460V/3Ph/60Hz Locking Plug & Receptacle  
Permanent Ball Valves for Refrigerant Serviceability  
Unit Caster Wheels

*Options available beyond features & accessories.*



## Refrigerant Storage & Recycling System



| MODEL    | FINAL VACUUM (IN.HG) | VAPOR RECOVERY RATE (LB/MIN) | LIQUID RECOVERY RATE (LB/MIN) | *REFRIGERANT CAPACITY (LB)<br>(% CAPACITY FULL) |       |                 |          |                 |       |
|----------|----------------------|------------------------------|-------------------------------|---|-------|-----------------|----------|-----------------|-------|
|          |                      |                              |                               | Refrigerant 80%                                 |       | Refrigerant 90% |          | Refrigerant 80% |       |
| RSR-4445 | 25.13                | 15.08                        | 483.91                        | CFC-12  | 5,684 | 6,394           | HCFC-22  | 4,582           | 5,155 |
|          |                      |                              |                               | CFC-500   | 4,386 | 4,934           | HFC-134a | 4,635           | 5,215 |
|          |                      |                              |                               | CFC-502   | 4,630 | 5,208           |          |                 |       |

\*Receiver Capacity based upon % full at 90°F per ASHRAE Standard 15-2007.

Industry Performance Leader

Non-standard tank sizes also available.

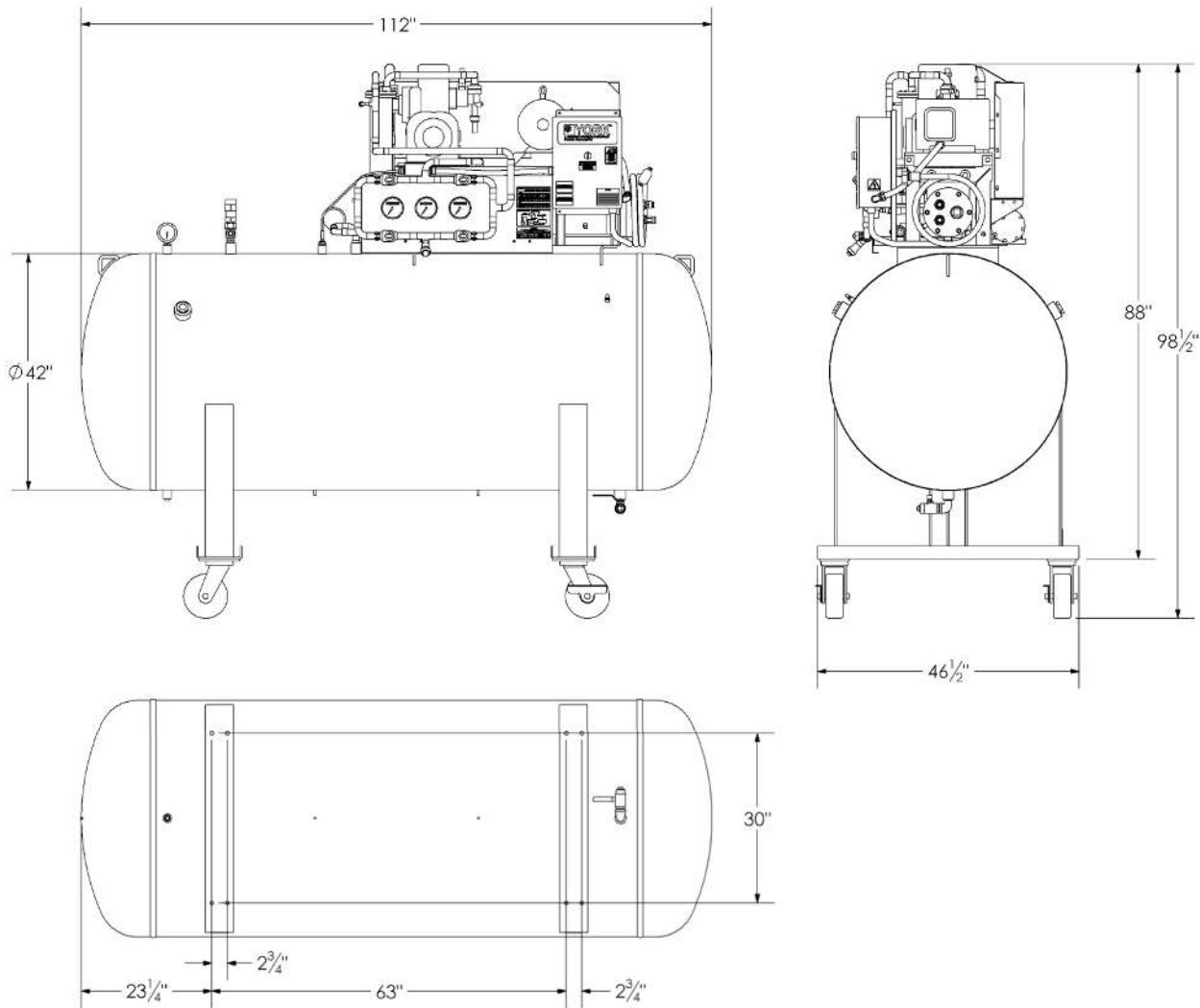

MOUNTING HOLE PATTERN (SHOWN WITHOUT CASTER ASSEMBLIES)